

P1000

Befestigungsprofil H41

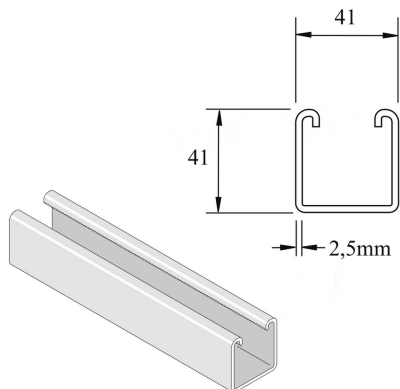

Standardausführung		Sendzimir verzinkt							
HD	Referenz	↕ mm	↔ mm	→ ← mm	↔ mm	kg/m	📦	Lager	Einheit
-	P1000P	41	41	2,5	6000	2,880	6	X	M
-	P1000	41	41	2,5	6000	2,880	6	X	M
-	P1000H	41	41	2,5	6000	2,880	6	X	M
-	P1000DF	41	41	2,5	6000	2,880	6	X	M
-	P1000PX3	41	41	2,5	3000	2,880	3		M
-	P1000X3	41	41	2,5	3000	2,880	3	X	M
-	P1000HX3000	41	41	2,5	3000	2,880	3		M

Abkürzung:

- PO = Unbehandelt
- ZP = Verzinkt
- HG = Tauchfeuerverzinkt
- DF = Defender