

WKS

Bolted bracket

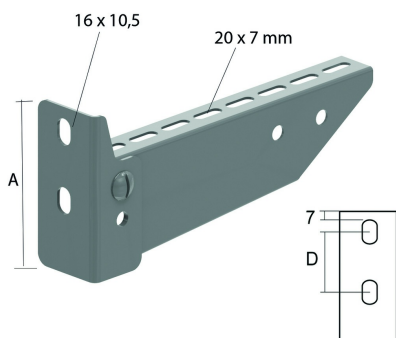

For direct fixing to walls and ceiling profiles

Standard finish	Pre-galvanised
Optional finish	Hot-dip galvanised
Optional finish PE	Coating

	Max. load (in daN)	A	D
WKS100	110	99	40
WKS150	110	99	40
WKS200	120	99	40
WKS300	130	119	60
WKS400	130	119	60
WKS500	140	139	80
WKS600	150	139	80

HD	Reference	↕ mm	↔ mm	→ ← mm	↔ mm	kg/stk	📦	Stock	Unit
HD	WKS100	99	117			0,240	12	X	STK
HD	WKS150	99	167			0,330	12	X	STK
HD	WKS200	99	217			0,380	12	X	STK
HD	WKS300	119	317			0,630	12	X	STK
HD	WKS400	119	417			0,760	6	X	STK
HD	WKS500	139	517			1,000	6	X	STK
HD	WKS600	139	617			1,230	6	X	STK

To order per full packaging.

For fixing to ceiling profiles, order the necessary fixing elements separately: two sliding nuts PNP10 and

- bolt B10.20 per bracket for ceiling profile HDHSLECL/HDHSLDCL.
- bolt B10.30 per bracket for ceiling profile HSMES/HSMD.

Max. load (in daN): uniformly distributed over complete width of cantilever brackets.