

P1000

Assembly profile

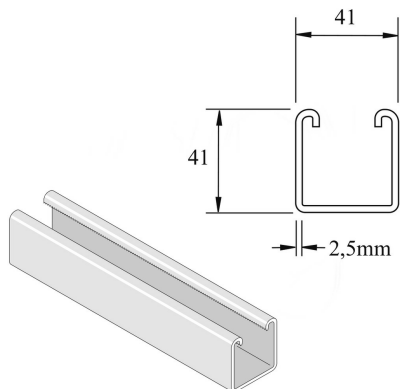

Standard finish		Pre-galvanised							
HD	Reference	↕ mm	↔ mm	→ ← mm	↔ mm	kg/m	📦	Stock	Unit
-	P1000P	41	41	2,5	6000	2,880	6	X	M
-	P1000	41	41	2,5	6000	2,880	6	X	M
-	P1000DF	41	41	2,5	6000	2,880	6	X	M
-	P1000PX3	41	41	2,5	3000	2,880	3		M
-	P1000X3	41	41	2,5	3000	2,880	3	X	M
-	P1000HX3000	41	41	2,5	3000	2,880	3		M

Abbreviation:

- PO = Plain Oil
- ZP = Zinc Plated
- HG = Hot-dip Galvanised
- DF = Defender