

P3300T10

Assembly profile

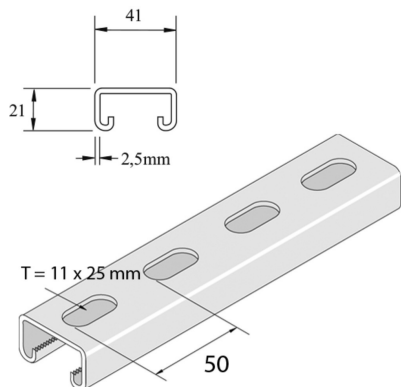

Standard finish		Pre-galvanised							
Optional finish		Coating							
HD	Reference	↕ mm	↔ mm	→ ← mm	↔ mm	kg/m	📦	Stock	Unit
-	P3300T	21	41	2,5	6000	1,570	6		M
-	P3300TH	21	41	2,5	6000	1,781	6		M
-	P3300TP10	21	41	2,5	6000	1,760	6	X	M
-	P3300T10	21	41	2,5	6000	1,760	6	X	M
-	P3300TH10	21	41	2,5	6000	1,760	6	X	M
-	P3300T10DF	21	41	2,5	6000	1,706	6		M
-	DUP3300TH10	21	41	2,5	6000	1,760	6		M
-	P3300TP10X3	21	41	2,5	3000	1,679	3		M
-	P3300THX3	21	41	2,5	3000	1,796	3		M
-	P3300T10X3	21	41	2,5	3000	1,760	3	X	M
-	P3300T10X2000	21	41	2,5	2000	1,570	2	X	M
-	P3300TH10X3	21	41	2,5	3000	1,760	3	X	M

Abbreviation:

- PO = Plain Oil
- ZP = Zinc Plated
- HG = Hot-Dip Galvanised
- DF = Defender