

# P1000

## Assembly profile

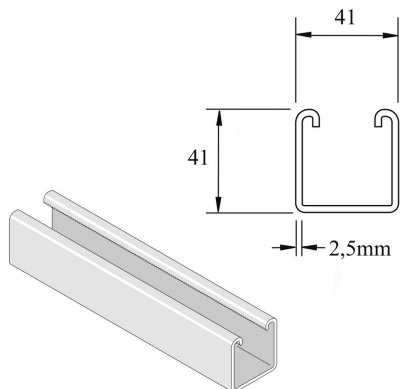

Reference	Finish	↕ mm	↔ mm	→  ← mm	↔ mm	kg/m	📦	Unit
<b>P1000P</b>	PO	41	41	2,5	6000	2,748	6	M
<b>P1000</b>	ZP	41	41	2,5	6000	2,792	6	M
<b>P1000DF</b>	DF	41	41	2,5	6000	2,880	6	M
<b>P1000PX3</b>	PO	41	41	2,5	3000	2,748	3	M
<b>P1000X3</b>	ZP	41	41	2,5	3000	2,880	3	M
<b>P1000HX3000</b>	HG	41	41	2,5	3000	2,880	3	M

**Abbreviation:**

- PO = Plain Oil
- ZP = Zinc Plated
- HG = Hot-dip Galvanised
- DF = Defender

**Legend finish**

- PO = Plain oil
- ZP = Zinc plated
- DF = Defender
- HG = Hot-dip galvanised