

# P3301T10

## Assembly profile

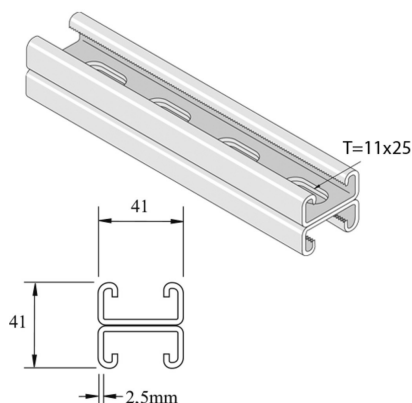

Reference	Finish	↑ mm	↔ mm	→  ← mm	↔ mm	kg/m	📦	Unit
<b>P3301T10P</b>	PO	41	41	2,5	6000	3,590	150	M
<b>P3301T10PG</b>	ZP	41	41	2,5	6000	3,422	6	M
<b>P3301T10DF</b>	DF	41	41	2,5	6000	3,530	6	M
<b>P3301T10PGX3</b>	ZP	41	41	2,5	3000	3,422	3	M
<b>P3301T10HX3</b>	ZP	41	41	2,5	3000	3,530	75	M

**Abbreviation:**

- ZP = Zinc Plated
- HG = Hot-Dip Galvanised
- DF = Defender

**Legend finish**

- PO = Plain oil
- ZP = Zinc plated
- DF = Defender