

# P1001

## Rail de montage

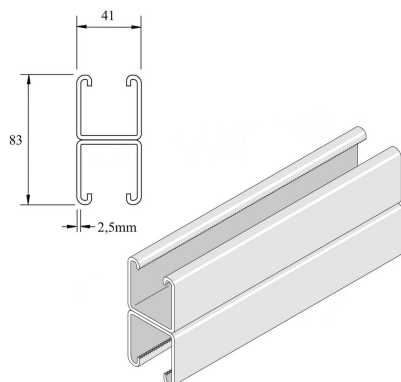

Exec. Std.

Sendzimir

| HD | Référence         | ↕<br>mm | ↔<br>mm | →  ←<br>mm | ↔<br>mm | kg/m  | 📦 | Magasin | Unité |
|----|-------------------|---------|---------|------------|---------|-------|---|---------|-------|
| -  | <b>P1001PG</b>    | 83      | 41      | 2,5        | 6000    | 5,744 | 6 | X       | M     |
| -  | <b>P1001</b>      | 83      | 41      | 2,5        | 6000    | 5,770 | 6 | X       | M     |
| -  | <b>P1001X3000</b> | 83      | 41      | 2,5        | 3000    | 5,770 | 3 |         | M     |

Abbréviation:

- ZP = Galvanisé
- HG = Galvanisé à Chaud