

P1001T

Rail de montage

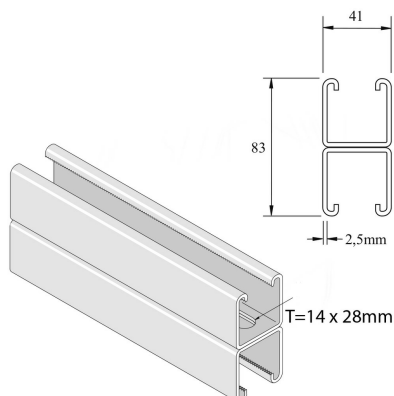

Exec. Std.		Sendzimir							
Mat. Opt.		Revêtement en poudre							
HD	Référence	↕ mm	↔ mm	→ ← mm	↔ mm	kg/m	📦	Magasin	Unité
-	P1001TP	83	41	2,5	6000	5,470	6	X	M
-	P1001TPG	83	41	2,5	6000	5,470	6	X	M
-	P1001TH	83	41	2,5	6000	5,470	6	X	M
-	P1001T10H	83	41	2,5	6000	5,467	6	X	M
-	P1001TDF	83	41	2,5	6000	5,303	6		M
-	P1001TPGX3	83	41	2,5	3000	5,470	3	X	M
-	P1001TDFX3	83	41	2,5	3000	5,303	3		M

Abbréviation:

- PO = Non Traité
- ZP = Galvanisé
- HG = Galvanisé à Chaud
- DF = Defender