

P1100T

Rail de montage

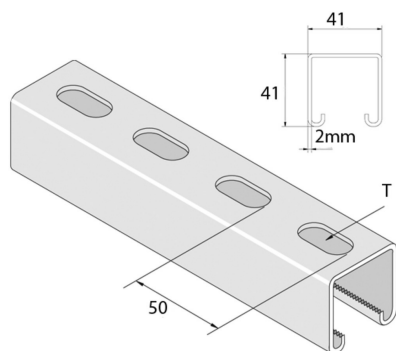

Exec. Std.		Sendzimir							
Mat. Opt.		Revêtement en poudre							
HD	Référence	↕ mm	↔ mm	→ ← mm	↔ mm	kg/m	📦	Magasin	Unité
-	P1100T	41	41	2	6000	2,184	6	X	M
-	P1100TH	41	41	2	6000	2,184	6	X	M
-	P1100TX3	41	41	2	3000	2,184	3	X	M

Abbréviation:

- ZP = Galvanisé
- HG = Galvanisé à Chaud