

P3300T10

Rail de montage

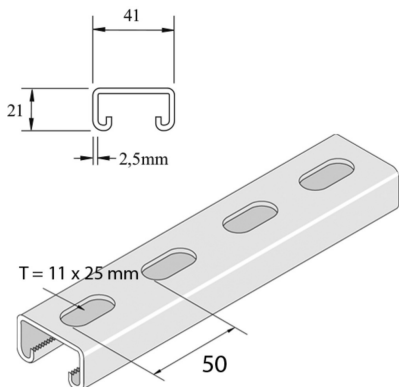

Exec. Std.		Sendzimir							
Mat. Opt.		Revêtement en poudre							
HD	Référence	↕ mm	↔ mm	→ ← mm	↔ mm	kg/m	📦	Magasin	Unité
-	P3300T	21	41	2,5	6000	1,570	6		M
-	P3300TDF	21	41	2,5	6000	1,781	6		M
-	P3300TP10	21	41	2,5	6000	1,760	6	X	M
-	P3300T10	21	41	2,5	6000	1,760	6	X	M
-	P3300T10DF	21	41	2,5	6000	1,706	6		M
-	P3300TP10X3	21	41	2,5	3000	1,679	3		M
-	P3300THX3	21	41	2,5	3000	1,796	3		M
-	P3300T10X3	21	41	2,5	3000	1,760	3	X	M
-	P3300T10X2000	21	41	2,5	2000	1,570	2	X	M
-	P3300T10DFX3	21	41	2,5	3000	1,706	3		M
-	P3300TH10X3	21	41	2,5	3000	1,760	3	X	M

Abbréviation:

- PO = Non Traité
- ZP = Galvanisé
- HG = Galvanisé à Chaud
- DF = Defender