

# P3301T10

## Rail de montage

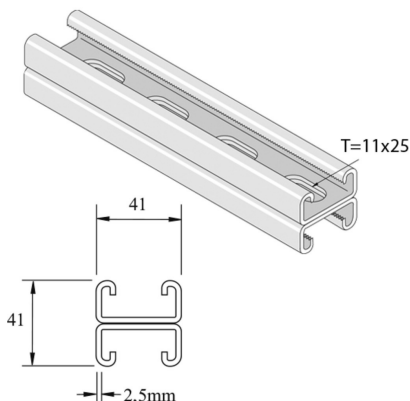

Exec. Std.		Galvanisé à chaud							
Mat. Opt. PE		Duplex							
HD	Référence	↕ mm	↔ mm	→  ← mm	↔ mm	kg/m	📦	Magasin	Unité
-	<b>P3301</b>	41	41	2,5	6000	3,760	6		M
-	<b>P3301TH</b>	41	41	2,5	6000	3,246	6		M
-	<b>P3301T10PG</b>	41	41	2,5	6000	3,530	6	X	M
-	<b>P3301T10H</b>	41	41	2,5	6000	3,530	6	X	M
-	<b>P3301T10DF</b>	41	41	2,5	6000	3,530	6	X	M
-	<b>P3301T10PGX3</b>	41	41	2,5	3000	3,530	3	X	M
-	<b>P3300T10DFX3</b>	21	41	2,5	3000	1,706	3		M

Abbréviation:

- ZP = Galvanisé
- HG = Galvanisé à Chaud
- DF = Defender