

# P3100T10

## Montageprofiel

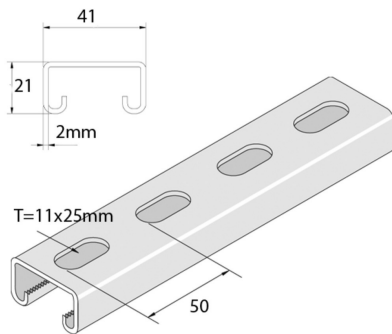

Stand. Uitv.		Sendzimir							
Mat. Opt. PE		Duplex							
HD	Artikel	↕ mm	↔ mm	→  ← mm	↔ mm	kg/m	📦	Stock	Eenh.
-	<b>P3100P</b>	21	41	2,0	6000	1,646	6		M
-	<b>P3100T10</b>	21	41	2	6000	1,408	6	X	M
-	<b>P3100TH10</b>	21	41	2	6000	1,408	6		M
-	<b>P3100T10X2</b>	21	41	2	3000	1,531	2	X	M
-	<b>P3100T10X3</b>	21	41	2	3000	1,408	3	X	M

Afkorting:

- PO = Onbehandeld
- ZP = Verzinkt
- HG = Hot-Dip Gegalvaniseerd