

P3301T10

Montageprofiel

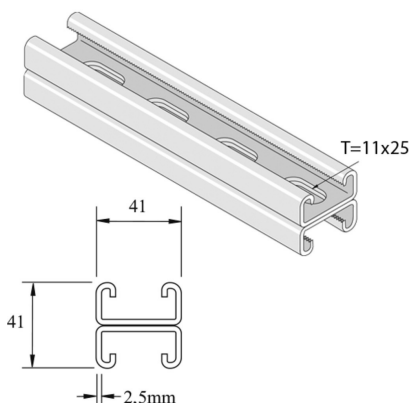

Stand. Uitv.		Hot-Dip						
Mat. Opt. PE		Duplex						
HD Artikel	↕ mm	↔ mm	→ ← mm	↔ mm	kg/m	📦	Stock	Eenh.
- P3301	41	41	2,5	6000	3,760	6		M
- P3301TH	41	41	2,5	6000	3,246	6		M
- P3301T10PG	41	41	2,5	6000	3,530	6	X	M
- P3301T10H	41	41	2,5	6000	3,530	6	X	M
- P3301T10DF	41	41	2,5	6000	3,530	6	X	M
- P3301T10PGX3	41	41	2,5	3000	3,530	3	X	M
- P3300T10DFX3	21	41	2,5	3000	1,706	3		M

Afkorting:

- ZP = Verzinkt
- HG = Hot-Dip Gegalvaniseerd
- DF = Defender